

Ethernet Surge Protection Device

Product Display

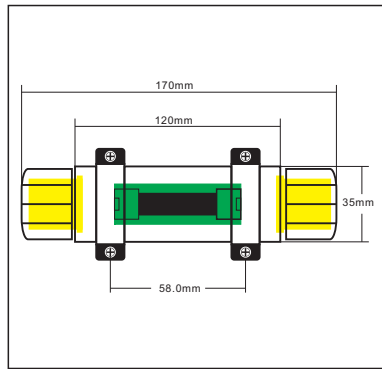

Application Diagram

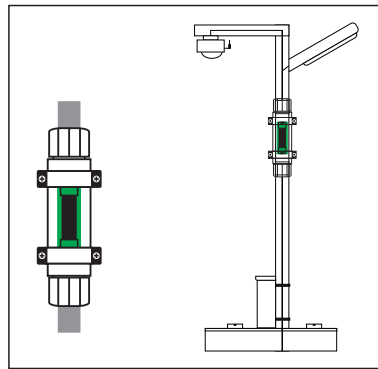

Schematic Diagram

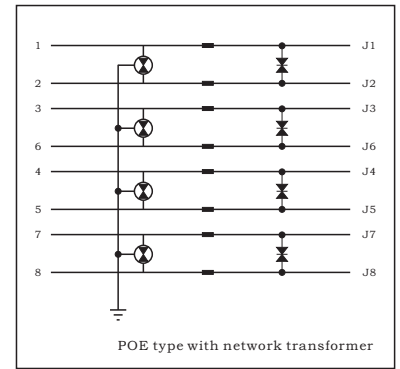

Product Application

- 5G Base Station System
- High Speed Data System
- Data Acquisition System
- Automation Industrial Equipment
- Outdoor Antenna System
- Signal Collection System
- Fire Alarm Network System
- Communication Network System

Product Feature

- Failure indication: Comloss
- Installation Type: Fixed
- Design Based in: IEC61643-21
- Design Based in: UL1449^{4th}
- Design Based in: GB/T 18802.21
- Protection: Rapid Technology
- Silk Screen Printing: Laser
- Output Type: RJ45 Junction
- RoHS&REACH Compliant

General Parameters

- Response Time: <100nS/<1nS
- Connection Type: Series
- Transmission Speed: 1Gbit/S
- Leakage Current: <1uA
- Protection Mode: Full Mode
- IP Class: IP68
- Above Sea Level: <5000m
- Relative Humidity: <95%(25°C)
- Operating Temp.: -50-+85°C
- Storage Temp.: -55-+125°C

Product Technical Parameters

Part Number	CSM-NET1G	CSM-NET1GPOE
SPD Application	Ethernet Surege Protection Device	
SPD Working Voltage (Uc)	5Vdc	48Vdc
SPD Maximum Continuous Operating Voltage (MCOV)	6.8Vdc	60Vdc
SPD Open Circuit Voltage (Uoc)	6kV	
SPD Nominal Peak Current In(8/20uS)	3kA	
SPD Maximum Peak Current Imax(8/20uS)	6kA	
SPD Voltage Protection Level (Up)	Line-Line: <70V/Line-PE: <300V	
SPD Load Current (I _L)	300mA	1800mA
SPD Differential Mode Protection	1-2, 3-6, 4-5, 7-8	
SPD Common Mode Protection	1/2/3/4/5/6/7/8-PE	
SPD Shell Material	Aluminum alloy oxidation treatment	
SPD Transmission Speed	1000Mbit/S	
SPD Failure Mode	Comloss	
SPD Extreme Use Temperature	-50°C-+85°C	
SPD Dimension (mm)	170*35mm(excluding installation components)	

Ordering Part Number:

Example:CSM-NET1GPOE

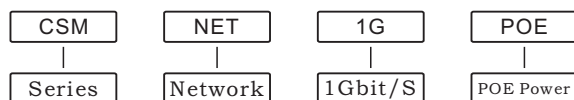

Note: Ethernet SPD has a variety of shell sizes. for details, please call the business department.

Product Use and Maintenance

- ◆ Ethernet SPD does not require special maintenance during normal use after installation. Due to the long-term exposure of the product to the air, in order to prevent remote false alarms caused by the failure of the ethernet SPD, its working status should be regularly checked, especially during frequent thunderstorms during the thunderstorm season. if any abnormalities are found, please replace the ethernet SPD of the same specification in a timely manner.
- ◆ When installing the ethernet SPD, please strictly follow the user manual or product specifications as a reference. if you have any questions, please call the manufacturer's technical support engineer. the on-site installation must be carried out by professional personnel complete homework operations.

Transportation and Storage Environment

1. Please pay attention to waterproof and moisture-proof measures during transportation to avoid infiltration into the packaging and oxidation of the surge protector wire.
2. Be careful not to withstand strong impacts and high-frequency vibrations to avoid damaging the appearance and shape of the product and damaging the surge protector.
3. If the product has been placed for more than one year, it is necessary to re inspect the product according to a strict sampling plan and check whether the lead wire is oxidized.

Package Information

- 1pcs/bag ● 60box/carton ODM/OEM
- 2pcs/box ● 45box/carton

*Packaging quantity of non-standard products may change, subject to actual delivery.

正意防雷®
competitor Manufacturer

Tel:+86-755-89587560
Fax:+86-755-28504421
Post Code:518112
E-Mail:support@csmspd.com
Website:http://www.csmspd.com
Add:351,Jihua Road SZ City P.R.C.

Thanks for choosing our product. if you need assistance, please contact us and we will handle it as soon as possible. Thank you!